

froeling 

S1 Turbo
Firewood boiler



S1 Turbo



www.froeling.com

Heating with firewood

For more than 50 years, Froling has specialised in efficiently using wood as a source of energy. Today the name Froling stands for modern biomass heating technology. The Froling firewood, wood chip, and pellet boilers are successfully in operation all over Europe. All of our products are manufactured in our factories in Austria and Germany. Froling's extensive service network ensures that we can handle all inquiries quickly.



froling

The fuel: Firewood (up to 56 cm)



Wood is a home-grown and environmentally friendly fuel, that is highly sustainable. It is CO₂ neutral and is not affected by international crises. The production of firewood and pellets ensures stable jobs in the industry. Looking at it from an environmental and economical point of view, wood

is the ideal fuel. The quality class is determined by the wood used.

S1 Turbo

The new S1 Turbo firewood boiler

Froling's new firewood boiler (15 - 20 kW) combines all the features of a state-of-the-art biomass combustion system. The speed-regulated induced draught fan ensures constant high quality combustion and the carbonisation gas extraction system prevents flue gas from escaping, even when topping up. The new S1 Turbo stands out for its high efficiency and long refilling intervals, combined with low emissions and low energy consumption.

The new air duct concept in Froling's S1 Turbo firewood boiler automatically regulates the heating air, primary air and secondary air with a single actuator. Thanks to the special air ducts for heating up, the fuel loading chamber door can be closed very soon after lighting. Heating with firewood can be that convenient!



The latest technology



The firewood boiler with special benefits:

- 1 Speed-regulated, low-noise induced draught fan for maximum ease of use.
- 2 Rectangular heat exchanger pipes with turbulators for optimum efficiency. With optional WOS system (lever mechanism for easy cleaning from the outside).
- 3 Large fuel loading chamber for logs up to 56 cm in length guarantees longer periods between refilling.
- 4 Top quality insulation to minimise radiant heat loss.
- 5 Lambdatronic S 3200 control with innovative bus technology.
- 6 Carbonisation gas extraction system prevents smoke escaping during reloading.
- 7 Cladding to protect the inner wall of the boiler and for a longer service life.
- 8 Air-cooled fuel loading chamber and cleaning door to minimise radiant heat loss.
- 9 Special automatic heat up with regulated air ducts.
- 10 Servomotor for automatic control of heating air, primary and secondary air.
- 11 High-temperature combustion chamber with firebrick lining (easy to replace parts).
- 12 Large cleaning port door for easy ash removal and cleaning from the front.

S1 Turbo



State-of-the-art technology and intelligent features



Feature: Large fuel loading chamber for logs up to 56 cm in length

Advantages:

- Easy loading
- Long combustion time
- Long reloading intervals

The S1 Turbo can burn firewood up to a length of 56 cm. It is conveniently filled from the front, and the large loading chamber ensures long intervals between reloading. The aprons protect the interior walls of the boiler, guaranteeing a long service life.

Intelligent features

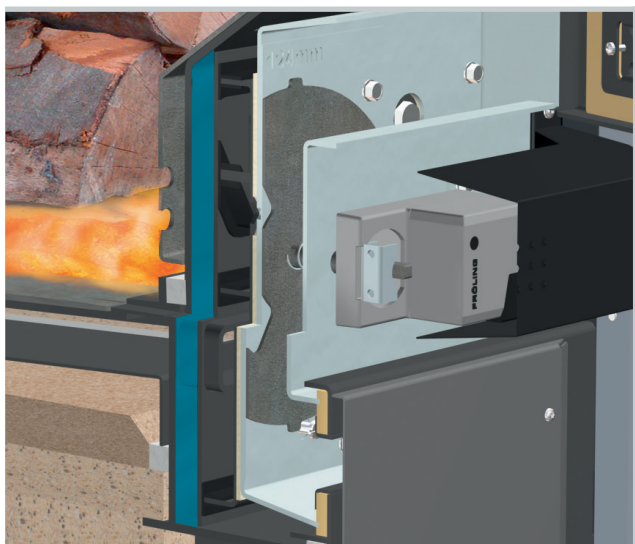

Feature: Unique air duct system

- Advantages:
- Regulated supply of air for heating up
 - Optimal combustion conditions

A unique design: Both the primary and secondary air as well as the heating air are automatically regulated in the new S1 Turbo with just one servomotor. This means that in every stage of the heating process - from heating up to burnout - the exact amount of air is supplied, creating the perfect combustion conditions. Furthermore, thanks to the regulated air supply for heating up, the door can be closed just a short time after lighting. Heating with firewood can be that easy!

Feature: High-temperature combustion chamber with firebrick lining

- Advantages:
- Low emissions
 - Easy cleaning
 - Long lifespan

The hot combustion zone in the combustion chamber keeps emissions levels low. The new shape of the combustion chamber makes it especially easy to clean. Furthermore, its new construction makes maintaining the combustion chamber a breeze as the firebricks are very easy to replace.

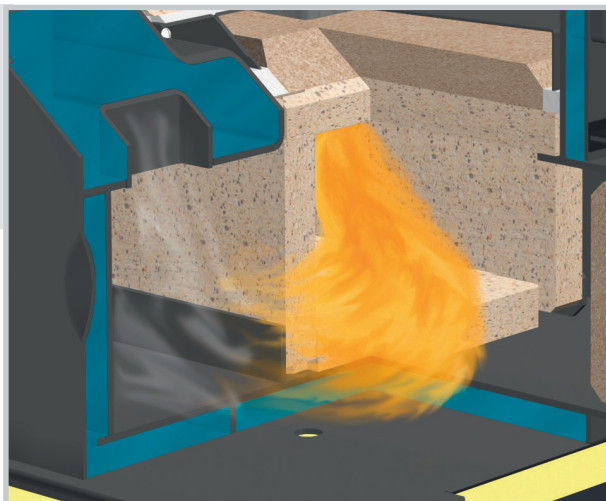

Feature: Air-cooled fuel loading chamber and cleaning doors

- Advantages:
- Maximum ease of use
 - Low radiant heat losses
 - High efficiency

Thanks to the new air duct concept, the combustion air is taken in via the fuel loading chamber and combustion chamber doors. This air cooling ensures low temperatures at the boiler's operating elements, thus offering optimum comfort for the user. Furthermore, the low radiant heat losses guarantee excellent efficiency.

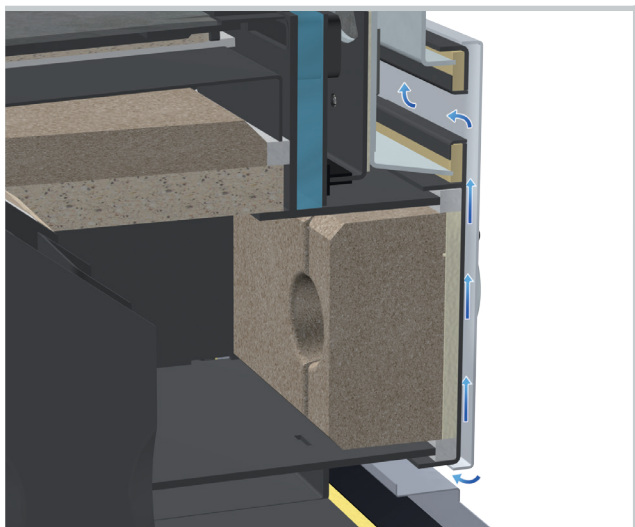

S1 Turbo

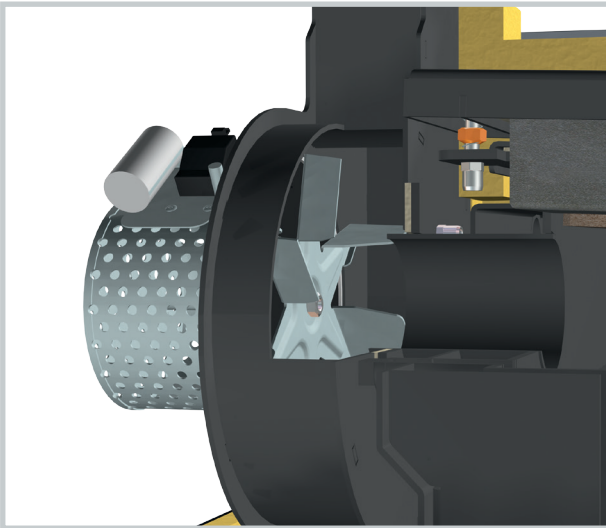

Feature: **Speed-regulated induced draught fan**

- Advantages:
- Maximum ease of use
 - Smooth boiler start
 - Constant stabilisation of combustion

The speed-controlled induced draught fan is a standard component of the unit, which further enhances the reliability of the S1 Turbo. This means that the boiler can be started easily even if the chimney is cold. The speed regulation device in the induced draught fan stabilises combustion throughout the heating process and adjusts the output according to requirements.

Feature: **Rectangular heat exchanger pipes with turbulators**

- Advantages:
- Improved heat transfer
 - High efficiency
 - Easy cleaning

The special insets in the heat exchanger pipes divert the flue gases within the heat exchanger several times, thus improving heat transfer and optimising efficiency. Furthermore, the turbulators can be moved manually and easily removed for cleaning. With optional WOS system (lever mechanism for easy cleaning from the outside).

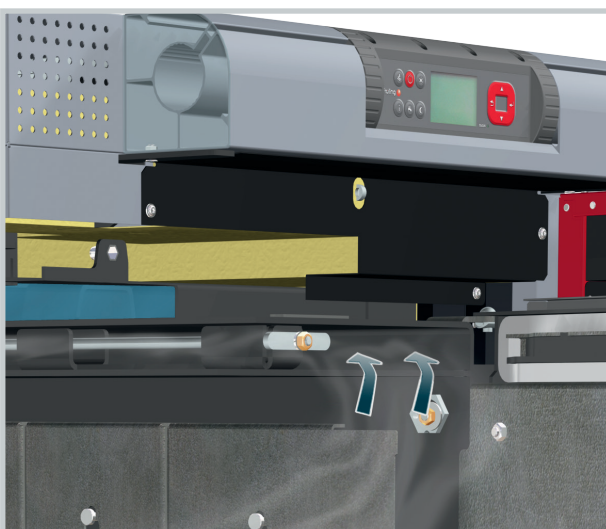

Feature: **Special carbonisation gas extraction system**

- Advantages:
- Easy heating up
 - No flue gas escapes during reloading
 - The boiler room stays clean

The integrated carbonisation gas duct flap makes heating up even easier. The flap is closed manually before lighting to provide a better draught during the heating up process. The carbonisation gas duct flap opens automatically when the fuel loading chamber door is closed. This then reactivates the carbonisation gas extraction system, thus preventing smoke and gas from escaping when reloading.

Systematic convenience

Feature: **Lambdatronic S 3200 control**

- Advantages:
- Exact combustion control thanks to lambda control with broadband probe as standard
 - Large, clear control unit
 - Control the heating from your living room (optional)



With the new S 3200 boiler control, Fröling is taking a step into the future. The control unit is optimised to suit any requirement. An individually adjustable viewing angle ensures that all operating statuses are clearly displayed. The lambda control ensures precise combustion. The menu structure is ideally organised to ensure easy operation. All essential functions can be selected by simply pressing a button. The boiler console is now also available with optional touch display.

The **Fröling bus system** makes it possible to install extension modules at any location. The local controls can be installed wherever they are needed: at the boiler, at the heat distributor, at the tank, in the living room or in the house next door. The S 3200 control allows up to 18 weather-compensated heating circuits, up to 8 water heaters and up to 4 storage tank management systems which can be connected. It can also control any type of differential controller; an oil or gas boiler, a solar panel or a system and a circulation pump. Additionally, electric cables are kept to a minimum. Only a bus cable is needed to control the room consoles.



The main modes of the designated heating circuit can be easily adjusted and selected using Fröling's **FRA room temperature sensor**. The adjusting wheel allows you to change the room temperature by up to +/- 3° C.

For even more convenience there's the **RBG 3200 room console** and the new **RBG 3200 Touch**. You can control the heating system easily from your living room. Important system data is clearly displayed and changes can be set by pushing a button.



NEW: Room console with touch display



The **RBG 3200 Touch room console** has an impressive modern touchpad interface. The menu structure is intuitive and easy to use. The 4.3" colour screen shows the most important functions at a glance and even automatically adjusts the background lighting to the conditions.

Feature: **Froling SMS Box**

- Advantages:
- Text message alerts
 - Active heating system control



The Froling SMS box allows you to monitor the boiler and actively control the heating system by text message. The SMS box can be directly programmed from a mobile phone. It has two error message inputs and two remote switch outputs. The alarm and message texts can be configured as required. This includes switching, e.g. from setback mode to party mode (only in conjunction with room temperature sensor). An automatic response confirms the execution of the command that was sent.

Feature: **Froling visualisation software 3200**

- Advantages:
- Monitor and operate from your PC
 - Record boiler data
 - Remote control via modem

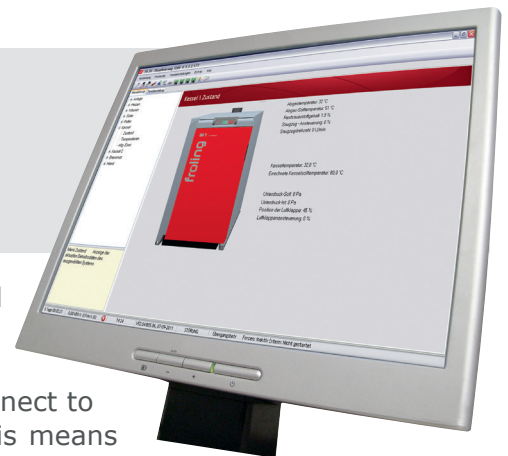

The optional boiler visualisation software enables easy boiler control from a computer. All operating values and customer parameters can be displayed and modified. The familiar Windows interface and clear menu structure make it easy to use. It is possible to connect to the visualisation software using a telephone network modem. This means that the heating system can be monitored from any location. It is also possible to connect to an existing LAN using an optional adapter.

Systematic convenience

Feature: Systems engineering for optimum energy consumption

- Advantages:
- Complete solutions for all requirements
 - The components work perfectly together
 - Integrated solar power

Froling systems engineering offers efficient energy management. Up to 4 storage tanks, up to 8 hot water tanks and up to 18 heating circuits can influence the heat management. You also benefit from the ability to integrate other means of energy production, such as solar panels.

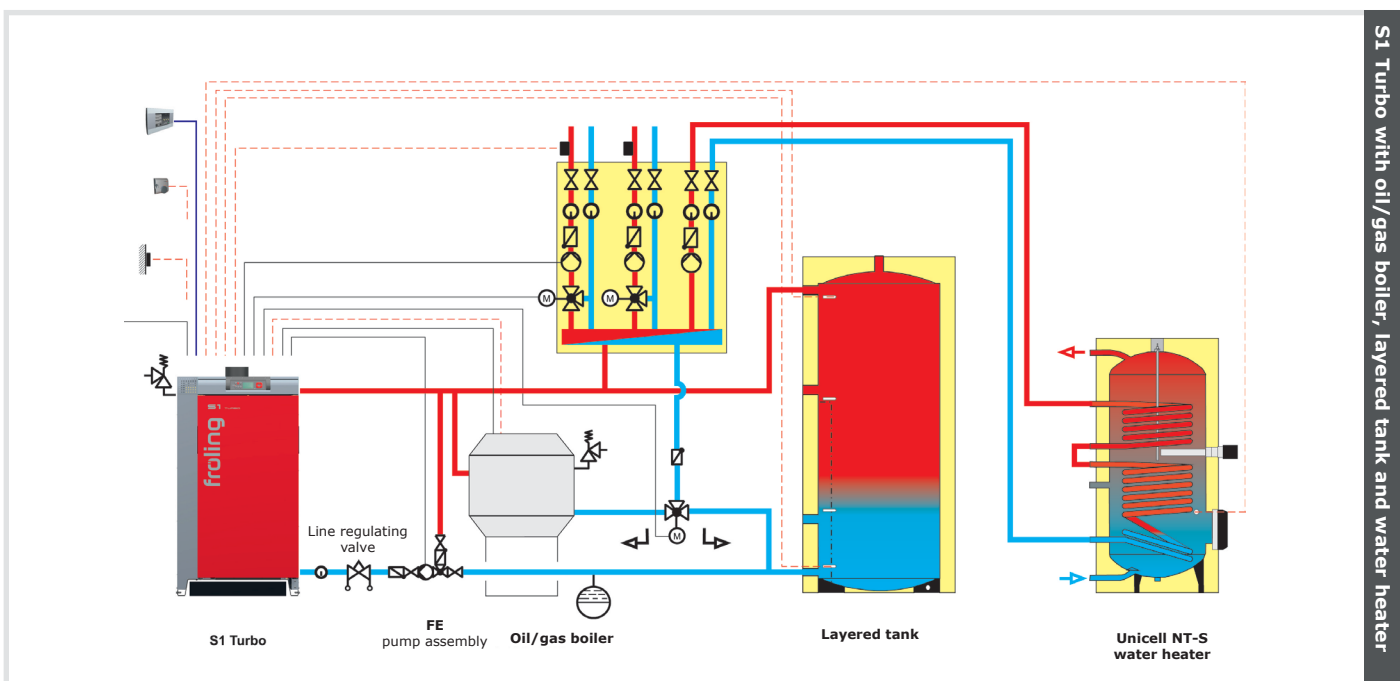
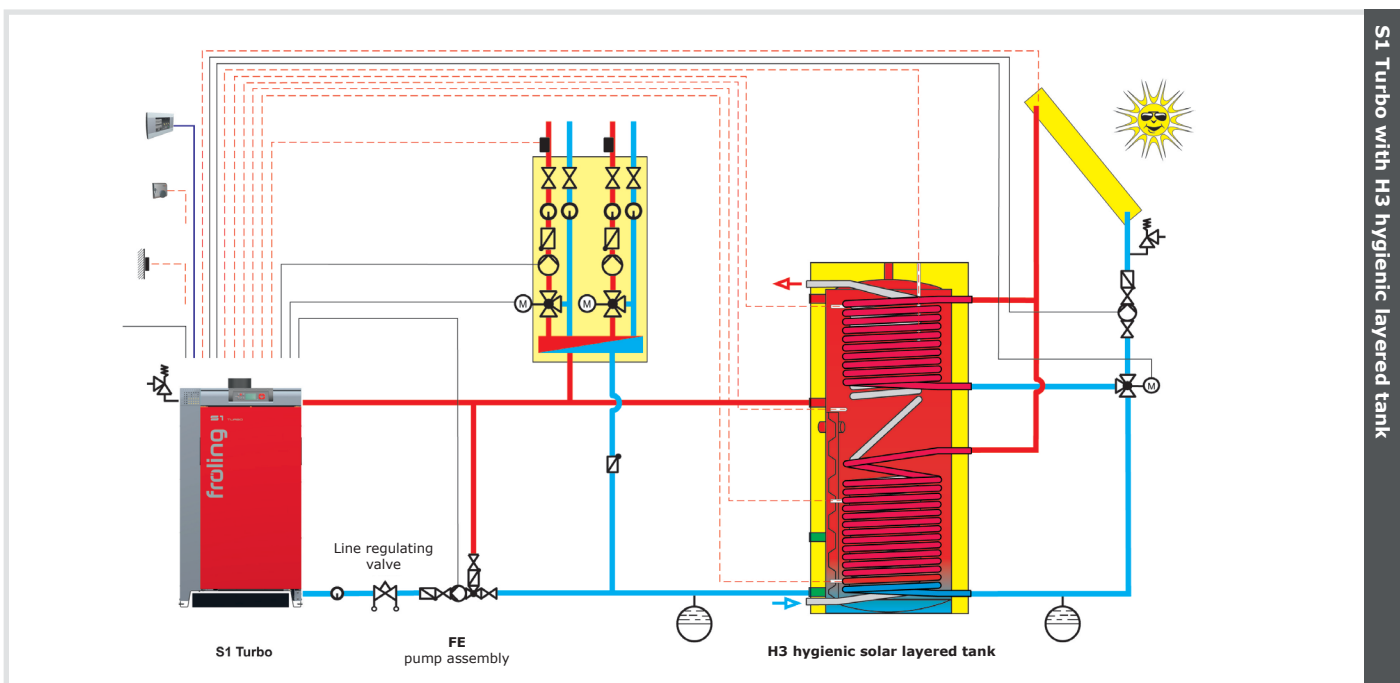

Minimum distances in the boiler room

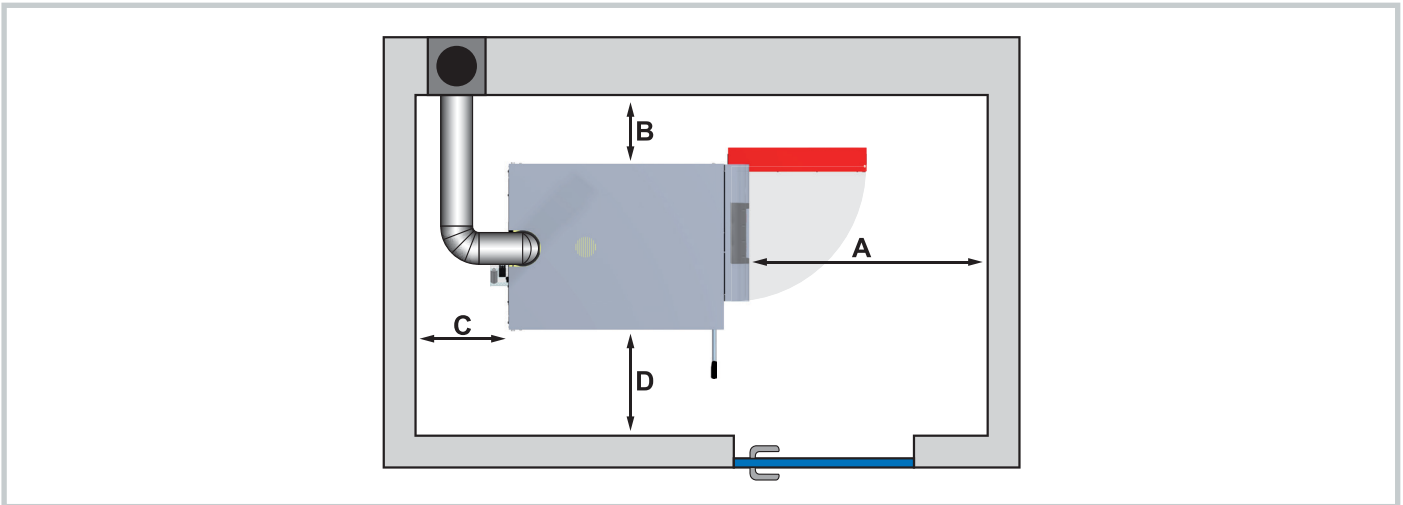

Minimum distances - S1 Turbo		15	20
A	Distance between front of boiler and wall [mm]	800	800
B	Distance between side of boiler and wall [mm]	200	200
C	Distance between rear of boiler and wall [mm]	400	400
D	Distance between side of boiler and wall ¹⁾ [mm]	500	500

1) In the model with optional WOS, the minimum distance on this side of the boiler is 500 mm.
 In the model without an optional WOS the following minimum distances are required: distance B 200 mm and distance D 500 mm OR distance B 500 mm and distance D 200 mm.

Technical specifications

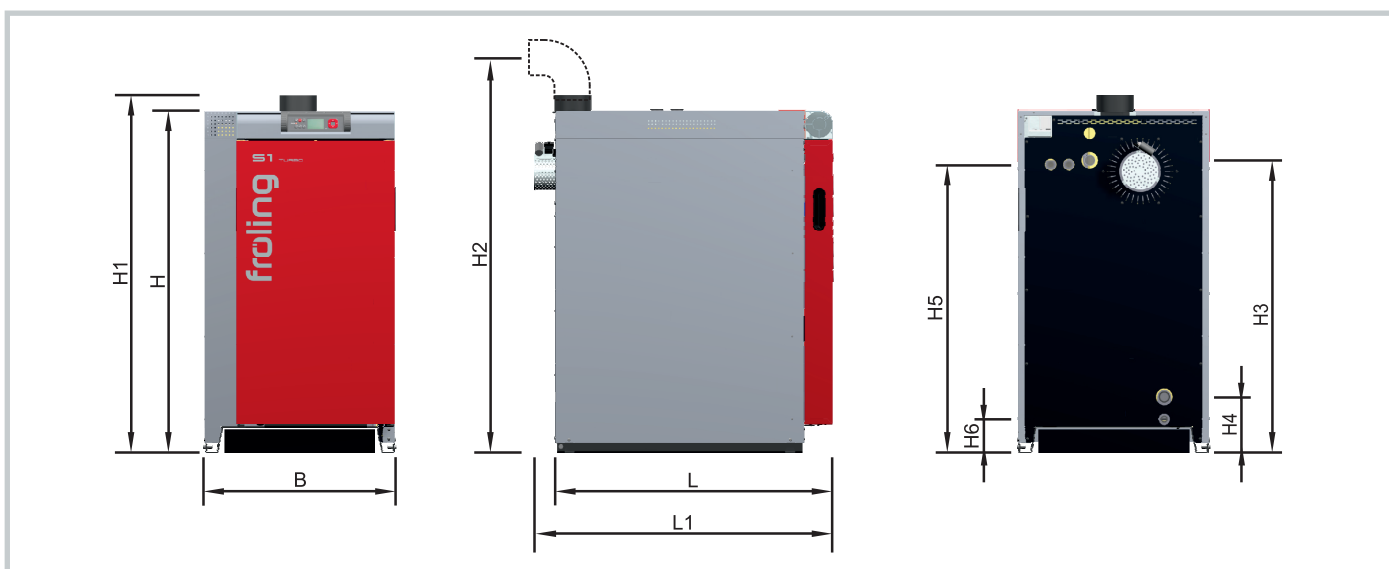

Dimensions - S1 Turbo		15	20
L	Length, boiler [mm]	1000	1000
L1	Total length incl. induced draught fan [mm]	1080	1080
B	Width, boiler [mm]	685	685
H	Height, boiler [mm]	1235	1235
H1	Total height incl. flue gas nozzle [mm]	1290	1290
H2	Height, flue pipe connection [mm]	1450	1450
H3	Height, flow connection [mm]	1055	1055
H4	Height, return connection [mm]	200	200
H5	Height, safety heat exchanger connection [mm]	1040	1040
H6	Height, drain [mm]	120	120
	Flue spigot diameter [mm]	130	130

Technical specifications - S1 Turbo		15	20
Nominal output	[kW]	15	20
Power connection	[V/Hz/A]	230V / 50Hz / fused 13A	
Power consumption	[W]	37	42
Weight of boiler incl. insulation and control	[kg]	455	465
Dimensions of fuel loading door (width/height)	[mm]	360 / 360	360 / 360
Fuel loading chamber capacity	[l]	80	80

Your Froling partner:

froling 

Heizkessel- und Behälterbau GesmbH
A-4710 Grieskirchen, Industriestr. 12
 AUT: Tel. +43 (0) 7248 606 • Fax +43 (0) 7248 606-600
 GER: Tel. +49(0)89927926-0 • Fax+49(0)89927926-219
 Email: info@froeling.com • Internet: www.froeling.com